

Re-Interpretation of Wicksell's Monetary Theory in an Intertemporal Equilibrium Model. Discussion of the Notion of a Monetary Equilibrium

Working paper

Isabel Rodríguez Peña¹

Summary

After the financial crisis in 2008, the relevance of disequilibrium in theoretical models became central. This seems reasonable since the crisis came about in a time where the disequilibrium was not part of dominant theoretical approaches. In this context, the aim of this paper is to analyze the incorporation of Wicksell's monetary equilibrium in a dynamic stochastic general equilibrium framework (DSGE), in particular within the New Neoclassical Synthesis (NNS) approach developed by Woodford (2003). This analysis concentrates on Woodford's work, since there the importance of Wicksell's monetary equilibrium is explicitly emphasized. However, the solution of Woodford's model expressed in the Taylor rule rejects the core idea of Wicksell (1898). The Wicksell monetary equilibrium explains the interrelation between the real and the monetary sector through disequilibrium. On the contrary, Woodford relates the equilibrium with the steady state where the equilibrium itself is an assumption not a result. The paper includes some central aspects of Wicksell's original concept of monetary equilibrium.

Keywords: Wicksell Monetary Theory, disequilibrium, NNS, Financial Crisis

Introduction: Discussion about “The State of Economics”

In the aftermath of the recent financial crisis a discussion about the ability of orthodox macroeconomic models emerged. The controversy focused on their capability to explain the crisis and in particular financial imbalances (see Stiglitz (2009) and Krugman (2009)). Still

¹ Investigadora posdoctoral en el Lateinamerika Institut en la Freie Universität bajo la supervisión de la doctora Barbara Fritz. The author is indebted to Barbara Fritz, Alejandro Marquez and Karl Zimmermann for helpful and valuable comments. Errors or omission are sole responsibility of author.

in 2008 Blanchard (2008) certified “good state” of macroeconomics². However, the financial crisis destroyed that conclusion and began discussion about the true “State of Macro”. The question was, why the financial crisis had not been anticipated and measures proposed and taken to fight it? Krugman (2009) argued that the problem lies in the vision of capitalism that the economists have, it refers to perfect or nearly perfect economic equilibrium. For that reason, after the economic crash in 1929, the economists did not believe that the financial system could start a new catastrophic crisis. In this context, the aim of this paper is to analyze the state of economic theory before the financial crisis. The discussion is focused on NNS, in particular the relevance of Wicksell’s monetary theory (W’sMT) within the new “Interest and Price”. This paper compares and discuss both views of notion of equilibrium, in particular, if the NCN recognizes absolutely the relevance of W’sMT within his framework.

In economic literature we can find some relevant discussion about the “State of Economics”. Some economists like Sitglitz (2009) and Krugman (2009) had argued that the problem lies in the introduction of financial sector. Other authors analyzed the fundamental elements of the model, in particular the assumptions of the dynamic stochastic general equilibrium model (DSGE) like Leijonhufvud (2011), Colander (2009) and Arestis & Sawyer (2008). Authors like Bianovsky (2005), Tamborini (2006), Barbaroux (2007), Tobon, A. and Barbaroux, N (2015), in particular, Rogers (2006, 2011), they analyzed the interpretation of Wicksell’s ideas in a NNS approach. In this context, the aim of this paper is contributing to the discussion about the theoretical crisis in the same direction of Rogers (2006, 2011), Bianovsky (2005) and Tobon *et all* (2015), however, I will focus in the notion of monetary equilibrium expressed in the Taylor’s Rule. Within this discussion, there are two important elements that I will consider in this paper. First of all, the relevance of original Wicksell’s monetary equilibrium (in particular, the relation between natural and monetary interest rate within a pure credit model) in comparison to Woodford’s neo-

² In the same direction Mankiw (1992) claimed that after “fifty years of additional progress in economic science, *The General Theory* is an outdated book. [...] We are in a much better position than Keynes was to figure out how the economy works.” Not true! Protests Saulus turned Paulus: “We have learned since September (2008) that the present generation of economists has not figured out how the economy works.”(Heinz, 2010:20).

wicksellian model, where the monetary equilibrium is related to real steady state. Secondly, the rejection of disequilibrium within steady state approach. That is to say, the most important distinction between Woodford and Wicksell is the notion about the monetary equilibrium.

The paper is divided in four sections. After this introduction, I will present a short basic framework of NNS. In particular, I will focus on the introduction of money and the financial market in a cashless model. In the same section, I am going to introduce some ideas about neo-Wicksell model. In the second section, I will analyze interpretation of W'sMT made by Woodford. In the third section, I am going to present some original ideas of Wicksell's monetary equilibrium, in particular the relevance of disequilibrium process or "accumulative process" inside of in the explanation of monetary equilibrium. In the last section, I will contrast both positions on the monetary equilibrium. La relevancia actualmente de la teoría de Wicksell en la discusión actual del estado de la ciencia económica,

1. The NNS framework and the incorporation of W'sMT.

The most important representation of NNS was developed by Woodford (2003). It follows the framework of King and Goodfriend (1997) and Woodford completes his model with the existence of a Central Bank in terms of W'sMT³. Woodford provides the basis for a wicksellian Central Bank behavior in the Taylor rule, where the existence of a natural rate is an essential point to build the equilibrium between real and monetary spaces. The relevance of W'sMT is central to NNS, for that reason Woodford called it the neo-Wicksellian model. NNS framework is developed in a sophisticated DSGE⁴, for that reason

³ The NNS is an expression of convergence within the Orthodox Theory. The starting point was the work of Marvin Goodfriend and Robert G. King (1997), they developed NNS. It incorporates important elements of neo- Keynesians, the monetarist school; New Classical and real business cycle theory each of the apparently irreconcilable traditions of macroeconomic thought (see Woodford 2009). Woodford (2009) argues that NNS had eliminated the old theoretical disputes (see Woodford 2009) and it represents the most important convergence within orthodox macroeconomics theory.

⁴ The DSGE synthesis sees the macroeconomic problem as a gigantic dynamic stochastic general equilibrium optimal control problem, and looks at the full optimization of individual and firms, arriving at a solution by using rational expectation and model consistency assumptions. [...]DSGE models consider agents who dynamically maximize their intertemporal objectives subject to budget and resource constraints within a

it is considered a model with a solid microfoundation. It includes a Central Bank and a financial sector inside a rational expectation model. According to Woodford (2003, chapter 2), the model has the following properties: 1) it provides an analytical framework that facilitates an orderly and systematic discussion, 2) it generates forecasts of principal macroeconomic variables and integrates effects of monetary policy on economy, 3) it has an analytical framework that incorporates risk and uncertainty around the baseline scenario, finally, 4) it develops models which support a regulatory apparatus of monetary policy. The result of this model is an optimal monetary policy. In the next section, I will develop the formulation of equilibrium price level. Subsequently, I will present some ideas of the wicksellian model developed by Woodford in 2003.

To understand the monetary policy in terms of a Wicksell's interest rate rule,⁵ that is subsequently called the Taylor rule, we start with a Fisher equation (see Woodford, chapter one). The equilibrium price level can be determined by the central bank's interest-rate response to price-level variations, without any reference to the associated fluctuations in any monetary aggregate (see Woodford 2003). We start with adjusted prices according to a modified Fisher-type equation ($p_t = E_t E_{p+1} + r_t - i_t$). Where i_t is a short-term nominal interest rate and r_t is a measured real rate of return. The latter express the equilibrium between aggregate saving and investment. The Wicksellian rule is introduced by ($i_t = \bar{i}_t + \phi p_t$) and it is introduced into the Fisher equation. After some modification we may obtain.

$$p_t = \sum_{j=0}^{\infty} \alpha^{j+1} E_t \alpha (r_{t+j} - \bar{i}_{t+j}) \dots (2)$$

The last equation represents the level of equilibrium prices fluctuating around a proportion of long-term value ($\bar{p} \equiv \phi^{-1}(\bar{r} - \bar{i})$). Where $\bar{r} - \bar{i}$ are the long-run average values of r_t , \bar{i}_t respectively. Therefore, the neo-Wicksellian model builds the equilibrium price level within a framework that depends only on real factors. This equation is an important element with which to introduce Wicksell's idea within "cashless economies". Woodford

variety of general equilibrium institutional settings that may include institutional and nominal rigidities (Colander, 2006: 5).

⁵"If prices rise, the rate of interest is to be raised; and if prices fall, the rate of interest is to be lowered; and the rate of interest is henceforth to be maintained at its new level until a further movement of prices calls for a further change in one direction or the other". (Woodford, 2003: 45)

(2003: 61) claims that “the Neo-Wicksellian framework, the fundamental determinants of the equilibrium price level are instead the real factors that determine the equilibrium real rate of interest, on the one hand, and the systematic relation between interest rate and prices established by the central bank’s policy rule, on the other.”

To introduce the monetary and the financial sector inside a cashless model is necessary to have the following conditions: the markets are perfectly competitive, there are complete markets, the prices are flexible and it adjusts continuously to clear market. In respect of the financial market, the model considers a frictionless financial market where the money can be related with any other asset (see Woodford 2003, chapter 2), that is to say, "state contingent securities of any kind may be traded" (Woodford, 2003, p.62). In addition, the representative household can hold both financial claims on government -such as bonds- and privately issued financial assets. Finally, the money is related to base money. In respect of the monetary policy, it takes the form of monetary rules where central banks stabilized the price level around an equilibrium price level. The key instrument for the central bank’s policy rule is the nominal interest rate on its liabilities.

The model is developed within an inter-temporal framework. It considers an economy made up of a large number of identical households. The representative household seeks to maximize the expected value of a discounted sum of period contributions to utility.

$$E_0 \left\{ \sum_{t=0}^{\infty} \beta^t \mu(C_t; \varepsilon_t) \right\} \quad \dots (2)$$

The utility function (equation 2) depends upon the level of consumption C_t of the economy’s single good. Where: $0 < \beta < 1$ is a discount factor; ε_t is an exogenous stochastic disturbance, $\mu(C_t; \varepsilon_t)$ is concave and strictly increasing in C . Subject to intertemporal budget constraint.

Under the assumption of complete markets, a household’s flow budget constraint (equation3) each period can be written in the form:

$$M_t + B_t \leq W_t + P_t Y_t - T_t - P_t \quad \dots (3)$$

Where M_t denotes the household's nominal end-of-period balances in the distinguished financial asset (or monetary base). It represents the economy's unit of account. B_t represents the nominal value (in terms of this unit of account) of the household's end-of-period portfolio of all other financial assets (whether privately issued or claims on the government). Therefore, the asset composition by the household is composed of central bank assets and other financial nonmonetary assets (private or public). W_t represents beginning-of-period financial wealth (now counting the monetary base along with other assets). Y_t is an exogenous (possibly stochastic) endowment of the single good. P_t is the price of the good in terms of the monetary unit, and T_t represents net (nominal) tax collections by the government.

The portfolio decision of the representative household is summarized by the choice of the state contingent value of A_{t+1} (nonmonetary assets) at the beginning of the next period. The variable A is a random variable which depends on the state of the world in $t+1$. In a cashless economy there is no benefit to holding money balances, therefore household optimization requires that $M_t = 0$ or $i_t = i_t^m$ ⁶ at each date and in each possible state.

We may now state the complete set of conditions for a rational expectation (or intertemporal) equilibrium in this model. In addition to the conditions just stated for household optimization, markets must clear at all dates. This means that household demands must satisfy at all dates: $C_t = Y_t$, $M_t = M_t^s$ and $A_{t+1} = A_{t+1}^s$. Here M_t^s refers to the supply of base money by the central bank, which we assume to be positive at all dates. A_{t+1} refers to the aggregate value at the beginning of period $t + 1$ of government bonds in the hands of the public at the end of period t (see Woodford 2003, chapter 2).

The intertemporal optimization of the utility is expressed in an IS equation⁷. It allows the interaction of output with the interest rate. The second equation, Phillips curve⁸, shows the influence of economic agent expectations on inflation and also considers the current output.

⁶ That is to say, that the nominal interest rate on the central bank liabilities (i_t^m) should equal the short-term riskless assets' interest rate (i_t).

⁷ ($Y_t = Y_0 - ar + \epsilon_t$) The IS curve derived from intertemporal optimization of the utility function, it reflects optimal consumption and saving decisions by the representative agent. It is structured under the micro-foundations and the intertemporal interaction (lagged and forward) by linking the output with the interest rate.

⁸ $\Pi_t = \Pi_{t-1} + \beta(Y_t - Y^T) + \epsilon_2$

Finally, equation 4 is the Taylor's rule or monetary policy equation. Those are the equations that composing the structural approach of NNS.

$$i_t = r^* + c_1 (\Pi_t - \Pi^T) + c_2 (Y_t - Y^T) \dots(4)$$

The central bank defines the monetary policy according the short-term market rate of the Taylor's Rule⁹, however, it does not consider any monetary factor (see Boivinovsky 2006) and in particular the model is unable to recognize the imbalances. Consequently, it only responds to inflation and output gaps. Within theoretical context, where the imbalances are related to gaps, the financial crisis arose.

Due to the financial crisis and the repercussion of financial imbalances, in 2010 Woodford recognized the importance of financial disequilibrium. He made an extension of the original model and introduced the concept of “demand for intermediation curve”. The idea was to introduce the financial intermediation like a solution to explain the eventual imbalances of output and inflation gaps. In order to recognize the imbalances, the “new model with intermediation” related the imbalances to gaps and the only difference in respect to the traditional model is the introduction of another agent that reduced the gap and established a new equilibrium position.

There are four important elements in the new model: i) deposits are not the only source of funding for the financial institutions ii) the savers fund intermediaries, who use the funds to lend to the ultimate borrowers, each agent reacts at a different interest rate, iii) there are multiple interest rates (the interest rate paid to savers i_s , and the interest paid on loans at which ultimate borrowers are able to finance additional current expenditure i_b), iv) the spread between interest rates can generate disequilibrium in credit market, so the intermediation is necessary to re-establish equilibrium.

The most important element to introduce the financial intermediation is the interest rate. In a single interest rate context, the equilibrium in credit market determines both a market clearing interest rate and an equilibrium volume of lending. However, inside an imbalances

⁹ The short-term nominal interest rate takes the form of a “Fisher equation” for the nominal interest rate, where the intertemporal marginal rate of substitution of the representative household plays the role of the real-interest factor. (see Woodford 2003, chapter 1).

model there are multiple interest rates (i_1 and i_2), consequently it is not possible to determine an equilibrium level of lending (see figure 1, left). The LS (loan supply schedule) shows the amount of lending L that ultimate savers are willing to finance for each possible value of the interest rate i received by savers. LD (loan demand schedule) shows the demand for such funds for each possible value of the interest rate that must be paid by borrowers.

Figure1. Spread of Interest Rate

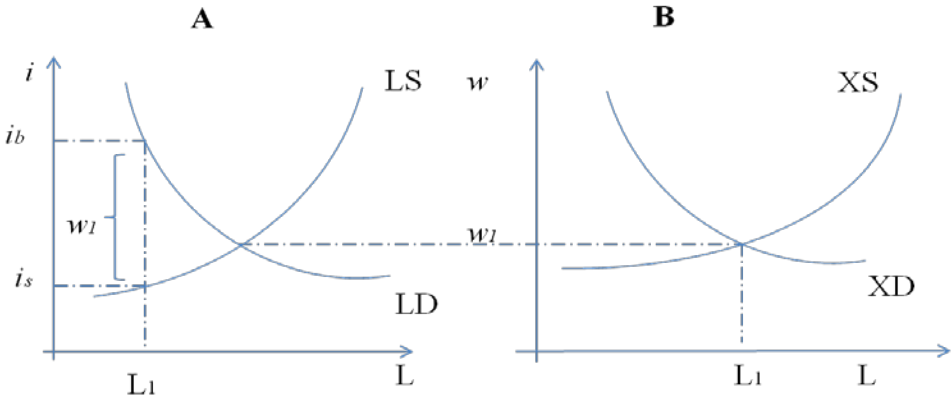

Source: Woodford 2010

The disequilibrium is motivated by differences between savers and borrowers. The Woodford solution is the correct spread to be determined by intermediaries, it becomes the variable of adjustment (similar to price) to ensure the credit market equilibrium. The intermediaries must eliminate the credit market gap through “demand for intermediation”, it is a curve XD that relates the quantity of intermediated credit and the credit spread (interest rate spread between savers and borrowers). The curve XS is the “supply of intermediation curve” and indicates the credit spread required to induce financial institutions to intermediate a certain volume of credit. The intermediaries are able to obtain a profit depending on the interest rate level that the ultimate borrowers are willing to pay to obtain the credit.

The equilibrium volume of credit and the correct spread are determined by the intersection between XD and XS (expressed by w_l), consequently the original problem (disequilibrium in credit markets) disappears. According to model, the equilibrium spread and volume of

credit are determined for a particular value of income (Y), therefore XD depends on it. For any level of i_s and Y we can obtain the IS curve. With these assumptions the financial intermediation is introduced within a traditional NNS, where there is a dependence on the supply of intermediation and consequently on the capital of intermediaries. That was the interpretation of the financial crisis by NNS, according with this framework the imbalances are related to a new equilibrium position. However, despite the effort made by introducing imbalances, it is related by gaps.

2. Classic Value Theory, Wicksell's Monetary Theory and EMH.

In the last section I presented some important elements within contemporary orthodox macroeconomic models. The central discussion was within two elements. First, the incorporation and interpretation of W'sMT inside a cashless model. Secondly, the interpretation of W'sMT into Taylor's rule. Both elements are strongly related to monetary interpretation and the place that it plays within NNS approach.

The most important relevance of NSS is that Woodford attempted to reconcile the classic values theory and the monetary theory through the W'sMT. Both theories were fused within an intertemporal framework. To complete the NSS approach, Woodford introduces the financial sector according to Efficient-Market Hypothesis (E-MH) developed by Fama (1970). The first argument follows the idea of intertemporal equilibrium models developed by Hicks in "Capital and Value" (1939). It is a re-interpretation of Walra's static general equilibrium model. The second argument is developed about the W'sMT (1898) in "Geldzins und Güterpreise" (1898), where the introduction of natural and monetary interest rates played an important place within the dynamic of an economic with pure credit. The NNS reconciles two different approaches, the link granting coherence to these two analyses is the existence of a central bank that intervenes, through a monetary policy (Taylor's Rule), on the variation of prices and the operating interest model.¹⁰

¹⁰ According to Woodford (2003: 54) "The neo-Wicksellian approach allows to establish the existence of a well-defined, econometrically stable money-demand relation, if one wishes to analyze the consequences of interest-rate rules such as the Taylor rule".

Another important part of this approach is the introduction of financial markets. The model does not clearly mention what happened with the financial market, however, it is introduced by E-MH (it can see in the equation 3). Respect of E-MH, it is addressed in the intertemporal budget constraint and the financial market is introduced according to complete market's idea. The complete markets assumption allows the introduction of any notation or the particular types of financial instruments that are traded. That is to say, the households can possess money or any other type of asset (assets without friction) (See Woodford 2003).

The first confusion with regard to this approach is introduced the W'sMT in order to introduce the money and credit within a traditional orthodox approach, like an intertemporal equilibrium approach. Trautwein and Boianovsky, (2001 p.500) argue that Wicksell's approach has to be used to understood as an attempt "to restate the quantity theory in credit-theoretical- terms". Tobon (2015) argued that the use of dynamic optimization "such as that developed by Woodford" does not contribute in a decisive way to improving our understanding of the role that money prices play in monetary theory. In spite of the framework introduced by the central bank, monetary interest rate and the financial marker, the model cannot understand the role of those played inside the solution. That is to say, the completely markets, frictionless financial asset and, in particular, the systematical solution to reduce the whole system, an equilibrium position like it would be the natural process to follow the economics system¹¹.

3. Wicksell before Woodford, Monetary Equilibrium in disequilibrium

The most relevant difference between Wicksell' and Woodford's is the concept of monetary equilibrium. Wicksell recognizes that the disequilibrium is a basic feature of economy. It is expressed between monetary and natural interest rates that generates accumulative process. According to Wicksell, the disequilibrium can explain the effect of credit on prices, demand of goods and unemployment. On the contrary, the NNS's equilibrium resulted in his assumption (ex-hypothesis), for example, the model assumes completely financial markets, any monetary and financial frictions and clear market in every period. The

¹¹ The argument of "the natural" was expressed by Hicks in Capital and Time (I need the foodnote)

disequilibrium can be only understood by random shocks or external effects which are temporary and do not affect the long-term of the optimal growth, these are expressed in output and inflation gaps. Therefore, in an intertemporal model the disequilibrium is only considered in term of gaps, in words of Colander (2014) “the basic macro scientific macro model is one of a stable economy where crises come from outside exogenous shock.”

Below I will present some ideas about W’sMT. I am going to emphasize the relevance of disequilibrium into a model with banks and pure credit. The W’sMT has been considering the most important contribution into the Classical Monetary Theory. Wicksell rejected Say’s Law and consequently Ricardo’s monetary theory, before Keynes (1930). It was a breaking point to views of the classical school in that moment (it was represented by works of Adam Smith, and especially of Ricardo and J. S. Mill). According to Wicksell, Ricardo’s monetary theory has not recognized the importance of disequilibrium and the relevance of banks within the functioning of economy system¹². However, the principal difference between both was that Wicksell rejected the classical uniform profit rate and introduced the marginal productivity of capital¹³. His argument was that short run there could be differences between aggregate and supply demand. This argument allowed **to** him to explain a change in prices as distinct from output. In the following, I present the most important variables within Wickell’s explanation. I am going to emphasize on agents and process to help explain the monetary prices within the disequilibrium process.

I will start with some concepts. The relevant variables that Wicksell use to explain the monetary theory are, pure credit; the Central Bank; the natural and monetary interest rates and save and investment. Wicksell extended the quantity theory to an economy with a banking system and pure credit. The introduction of credit had an important repercussion

¹² Wicksell cuestiona la forma imperfecta mecánica del principio cuantitativo de la moneda. La formulación ricardiana asimila los billetes a las piezas metálicas y no explica el mecanismo utilizado por el banco para introducir una cantidad de moneda en la circulación. La incorporación de la tasa de interés monetaria y la tasa de interés real, queda atrapada en la interpretación tradicional de la Ley de Say. En el análisis ricardiano – añade Wicksell- el crédito bancario carece de especificad; la introducción de las cantidades suplementarias de nómina son imposibles, por consiguiente, es imposible esclarecer la naturaleza el desequilibrio monetario. Por lo tanto, Ricardo no puede justificar como la demanda de dinero se iguala a la oferta y por consiguiente sólo se limita a postular una relación entre cantidades de dinero y nivel general de precios” (Solis, 1999: 33).

¹³ The marginal prouctivity of capital was developed by Austrian School, especially by Böhm Bawerk and Menger.

on velocity of circulation. According to Wicksell the credit is a basic characteristic of this new born capitalism. It has a direct effect on the velocity of money and the prices. Respect to velocity of money, the credit is considered as accelerating the circulation of money.

His interest was to explain, how an increase in the quantity of money in an economy with pure credit to ultimately brings it to a new equilibrium position with a higher price level. Wicksell explained the movement of prices according to indirectly effect, where the prices increased due to the banks offers more credit to the household, that it to say, the raising is associated to low or falling of monetary interest rate below natural interest rate.

In an economy in which money circulated as the main medium of exchange, an increase in the quantity of money generated a direct upward pressure on price. But, Wicksell asked, how was such a pressure generated in an economy in which most of the money accrued not to individual, but the banks to be held as a reserve against their deposits.

Wicksell had recognized the importance of money as a medium of exchange or a means of payment, that is to say, the period between a sale and a subsequent purchase or, more generally, between a payment received or advanced and a payment by the receiver. Respect to interest rates, the natural rate is, by nature, a fluctuating rate in spite of the monetary rate behaves steadily and in sticky way because of the routinely bankers' behavior. Wicksell (1907: 213) argued “[...] interest on monetary and profit on capital are not same thing, nor are they immediately connected with each other There is no way of thinking that both rates should be equal, according to Wicksell's explanation the difference between both interest rate allowed to explain the accumulative process. The last argument is the principal difference respect to neoclassical theory, Wicksell argued that money and real capital can never trade as if they were the same thing. Wicksell's own words “Economists do not tire of impressing on their students that money and real capital are not the same thing, that interest on capital and interest on money are consequently different things” (1907, p 213, Lecture, volume II).

Another important different, respect to the traditional quantity theory, in Wicksell's explanation the saving and the investment not is an equality. The gap between saving and investment allow to analyze the movements in nominal income stems from it and to explain

the relation between money and price through accumulative process. In a traditional quantity theory, the saving and the investment determine the composition of output, but have any relation with level of income.

According to Wicksell the economy consisting of three different sectors: households, firms and banks. The banking system behavior is relevant to understand the relation between the household and the business sector in terms of circular flows. Household saving flow into a business investment finance flow out of banks (see figure 2). Finally is important to mention that the model assumes fully employed (see lectures II, P.195).

Figure 2. Flow between Banks, Households and Firms

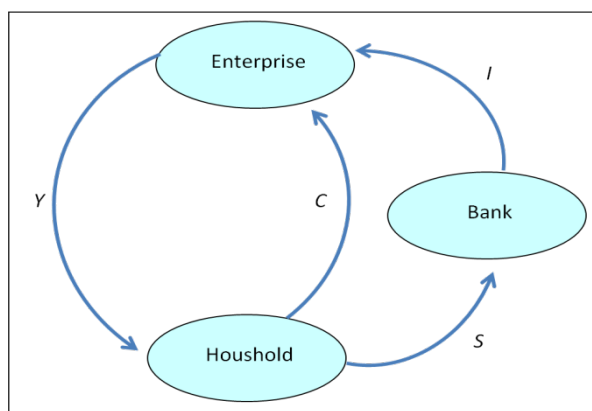

Source: Leijonhufvud 1979.

The accumulative process beginning when the lending interest rate (i_m) falls below the natural interest rate (i_n). It produces an expansion of bank credit due it is cheaper. The Central Bank (CB) taken the decision to reduce the landing rate because they find an excess reserves, therefore, it decides to expand their loans (Cs). The resulting of expansion on demand deposit will generate an increase in “general demand” (D). Thus “general demand” (D) becomes greater respect to the supply, causing a general rise in both prices (P) and wages (W). This induces entrepreneurs to borrow (C^D) and use the process to increase their demand for investment goods (IG); it also causes a decrease in savings (S) or, what is the same thing, an increase in the demand for consumption goods (FCG) and consequently increasing all prices. The expansion of IG produces an increased in employment (E) and the wages raise (W) (see figure 3) (see Patinkin, 1982).

Figure 3. Cumulative Process

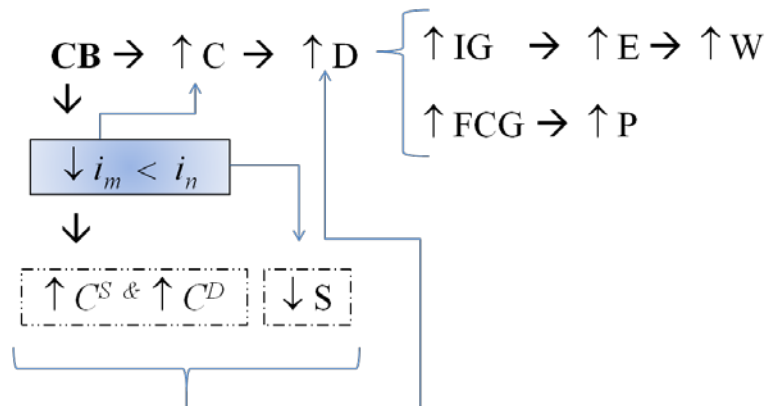

Source: our

In this way, the banks disturbed prices through of their rate of interest on credit. That process produces a cumulative process where the prices are represented by a dynamic phenomenon acting like a “spiral spring which serves to transmit the power between the natural and the money rate of interest” (see Wicksell, 1907: 200, Lecture, volume II). The process stopped when the monetary authorities intervened. The Central Bank had occasioned the falling of monetary rate and when the bank reserves depleted, the lending rate raised (it returns to the same natural interest rate). In that sense, discrepancy is the norm which legitimates the intervention of monetary authorities, such as the central bank, to correct this market failure.

The increase of investment demand (IG) produces more employment and high wages. At the end of the process all prices are higher respect to the beginning. The capital accumulation does not change because after the accumulative process the natural interest rates are the same. Respect to credit market, it is higher at the end of process.

3.1. Are Real and Monetary Equilibrium the same?

I mentioned the relevance of disequilibrium in W’sMT, in particular, the formation of monetary prices. One of the most important part is the movement between the real and the monetary interest rates within the dynamic system, because the disequilibrium allowed the explanation of monetary prices. However, Woodford’s interpretation rejected the most important element of W’sMT, therefore, the problem arose when it is developed in a

cashless economy where the disequilibrium is related to gap. That is to say, Wicksell's theory has been interpreted by Woodford within a neoclassical approach. In this context, the role of money is impossible to introduce within cashless model and, consequently, the monetary theory is undefined.

In this context, the aims of this section is focused on the discussion between a real or natural and a monetary frameworks. It is relevant because according to Woodford's model, the most important part of this new approach is introduction of the Central Bank, credit, monetary interest rate, financial market and financial intermediation, however, these are introduced within a traditional orthodox approach like a cashless model. That is to say, it is another traditional model that introduces the monetary sector but the solution is like if it was a real model (Tobon and Barbaroux 2015, Rogers 2010). Consequently, the confusion arose from develop a monetary model inside real approach.

For example, a cashless model, that include perfectly competitive markets and, specially, complete financial markets, can no introduce the financial imbalances. In the section one, I mentioned that the conception of monetary equilibrium within NSN is consistent with zero output gap and constant inflation. That is to say, the equality between natural and monetary interest rate guaranteed the monetary equilibrium. However, that argument has two implications. The first has been expressed by Boinovsky (2006); he argues that the Central Bank follows the Taylor's Rule and directly control the short-term market rate it, however it does not consider any monetary factor. The natural interest rate is defined in real terms and it cannot establish any relation with monetary interest rate, because, it is an expression of intertemporal preference of consumption. That is to say, it reflects the comparison between present consumption and future consumption in terms of discounting the future. Secondly, the disequilibrium is related by gaps of inflation and output. That is to say, it is caused by incompletely information. Therefore, both implications could only occur inside a cashless model.

Figure 4. Real and Monetary Equilibrium

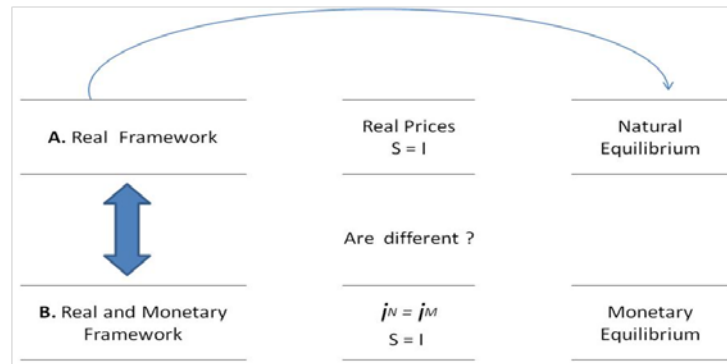

Source: Own elaboration.

In monetary terms, the problems with this new monetary treatise are two: 1) it is defined in terms of a cashless model where perfectly competitive markets and, specially, complete financial markets rejected any possibility to introduce the financial imbalances. 2) the monetary policy is defined by Taylor Rule and the equilibrium between the real and monetary space. The principal variable (natural interest rate) is expressed in terms real.

Therefore, despite of NNS introduce the notion of monetary equilibrium developed by Wicksell, his interpretation is trapped in the traditional interpretation of Say's law (see Rogers 2006). He argues that "Woodford is a victim of the same well-known criticism as that concerning the models of integration of money into the Neoclassical Walrasian General Equilibrium Theory of the Arrow-Debreu type" (cited Tobon and Barbaroux 2015). That is to say, the use of dynamic optimization does not contribute to improving our understanding the monetary theory.

Wicksell's proposal provide a monetary theory within a pure credit model that is completely different to a cashless economy framework. Woodford's approach is a new model with a proposal monetary policy, however, his conclusion is completely different respect to Wicksell

Some comments (*work in process*)

References

Barbaroux, N. and von Ossietzky, C. (2005). "The Role of History in Wicksell's Methodology" 9th Annual Conference of the European Society for the History of Economic Thought (ESHET), STIRLING (Scotland), June 2005.

Barbaroux, N (2007). “Wicksell and Woodford: a Cashless Economy or Moneyless Economy?” ujm-00162418, version 1 - 13 Jul 2007.

Blanchard, O (2008). “The state of macro” Working Paper 14259 <http://www.nber.org/papers/w14259>

Boianovsky, Mauro and Trautwein, Hans-Michael (2001) “Wicksell’s lecture notes on economic crises (1902/05)” *Structural Change and Economic Dynamics*, 12 (2001), 343–366.

Boianovsky, Mauro and Trautwein, Hans-Michael (2004) “Wicksell after Woodford.” This paper was presented at the History of Economics Society meeting at Toronto in June 2004.

Boianovsky, Mauro and Trautwein, Hans-Michael (2005) “The New Neoclassical Synthesis: A Wicksellian Renaissance?” This paper is a preliminary version, prepared for the conference on The History of Macroeconomics at the Université Catholique de Louvain, January 20-22, 2005.

De Vroey, Michel (2000) “Equilibrio y desequilibrio en la teoría económica: una confrontación de las concepciones Clásicas, Marshallianas y Walras-Hicksiana”, análisis económico, primer semestre, año/vol. XV, número 031, Universidad Autónoma Metropolitana, 59-89.

Goodfriend, Marvin y Robert King (1997). “The New Neoclassical Synthesis and the Role of Monetary Policy”. En: National Bureau of Economic Research.

Heinz, Kurz (2010), “On the dismal state of a dismal science? Investigación Económica”, vol. LXIX, núm. 274, octubre-diciembre, 2010, 17-41.

Kates, S. (2013), *Defending the History of Economic Thought*, Edward Elgar.

Krugman, Paul (2009), “How Did Economists Get It So Wrong?” <http://www.nytimes.com/2009/09/06/magazine/06Economic-t.html?pagewanted=all& r=0>

Krugman, Paul (2009), “How Did Economists Get It So Wrong?” En: *New York Times*, September 2, 2009.

Leijonhufvud, Axel (2011). “Nature of an economy”. UCLA and University of Trento. February 2011, To download this and other Policy Insights, visit www.cepr.org, Trento, Italia.

Leijonhufvud, Axel (1979). “The Wicksell connection, variation on a theme”. Report No. 23/78. University of California, Los Angeles, Estados Unidos.

Leijonhufvud, Axel y Leandro Wolfson (2000), “Ms. Keynes y los Modernos”.

Leijonhufvud, Axel, (1997), *The Wicksellian Heritage*, No 9705, Department of Economics Working Papers, Department of Economics, University of Trento, Italia, <http://EconPapers.repec.org/RePEc:trn:utwpede:9705>.

- Patinkin, Don ([1956] 1963). *Dinero, Interes y Precios*, Aguilar, Madrid.
- Patinkin (1982), *Anticipations of the General Theory?: And Other Essays on Keynes*, The University of Chicago, USA.
- Perrotini, I. 2007, “El Nuevo Paradigma Monetario”, en *Economía UNAM* núm. 11, mayo-agosto, UNAM, pp. 64-82.
- Rogers, C. (2006) ‘Doing without money: a critical assessment of Woodford’s analysis’, *Cambridge Journal of Economics*, 30 (2): 293-306.
- Rogers, C. (2011) ‘The Failure of Woodford’s Model of the Channel System in the Cashless Economy’, *Journal of Money, Credit and Banking*, 43 (2-3): 553–563.
- Solis, Ricardo (1999), *Banco Central y Tasa de Interés*. Universidad Autónoma Metropolitana unidad Xochimilco e Instituto Politécnico Nacional, México.
- Stiglitz, Joseph (2009), “Davos Man’s Depression“ . Feb. 4 2009. <http://www.project-syndicate.org/commentary/davos-man-s-depression>.
- Tamborini, R. (2006), “Wicksell. Keynes and the New Neoclassical Synthesis. Whither saving-investment imbalances?” Paper presented “Third International Conference: “Developments in Economic Theory and Policy””; Bilbao, 6th-7th July 2006.
- Tieben, Bert (2012), *The Concept of Equilibrium in Different Economic Traditions*, Edward Elgar, Cheltenham, UK.
- Tobon, A. and Barbaroux, N (2015), “Credit and Prices in Woodford’s New Neoclassical Synthesis” *Economic Thought* 4.1: 21-46.
- Wicksell, Kunt (1898[1962]), *Interest and Prices, A study of the causes regulating the value of money, Volume One*, Royal Economic Society.
- Wicksell, Kunt (1898[1962]), *Interest and Prices, A study of the causes regulating the value of money, Volume Two*, Royal Economic Society.
- Woodford, Michael (2003), *Interest and Prices: Foundations of a theory of monetary policy*, Princeton University Press.
- Woodford, Michael (2009), “Convergence in Macroeconomics: Elements of the new Synthesis”, *American Economic Journal: Macroeconomics*, 267-279.
- Woodford, Michael (2010), “Financial Intermediation and Macroeconomic Analysis”, *Journal of Economic Perspectives* 24, 21-44.